



## MULTIDECK DISPLAY FRIDGES

instruction manual

---





## OPERATING INSTRUCTIONS FOR UPRIGHT REFRIGERATED CABINET (REGAL) ADX

Dear Customers! Read the manual of the upright refrigerated cabinet before you start using it,  
which will ensure long and efficient operation of the equipment!

### Table of contents

1. General information . . . . .	4	4.2.2. Checking the set temperature . . . . .	20
2. Technical Specifications . . . . .	5	4.2.3. Changing the temperature . . . . .	20
3. Transportation, installation and commissioning . . . . .	6	4.2.4. Manual defrost request . . . . .	20
3.1. Transportation method . . . . .	6	4.2.5. List of alarms . . . . .	20
3.2. Storage method . . . . .	6	5. Preservation . . . . .	20
3.3. Operating site requirements . . . . .	6	5.1. Cleaning and preservation . . . . .	20
3.4. Equipment installation and preparation for operation . . . . .	6	5.1.1. Cleaning the equipment . . . . .	21
3.5. Connection and commissioning . . . . .	6	5.1.2. Defrosting the evaporator . . . . .	21
3.6. Operation of energy-saving night blinds (curtains) . . . . .	8	5.1.3. Condenser maintenance . . . . .	21
3.7. Assembling a line of refrigerated multideck ADX . . . . .	9	5.1.4. Miscellaneous . . . . .	22
4. Operation . . . . .	19	6. Identifying and correcting malfunctions . . . . .	22
4.1. Operating procedure of the CAREL electronic controller . . . . .	19	7. Disposal . . . . .	24
4.1.1. Light signals on the electronic controller display . . . . .	19		
4.1.2. Temperature setting . . . . .	19		
4.1.3. Additional defrosting . . . . .	19		
4.1.4. Warning signals . . . . .	19		
4.2. Operating procedure of the Dixell electronic controller . . . . .	19		
4.2.1. Display . . . . .	19		



**Dear customer! If you have purchased equipment operating with R290 refrigerant, please read the reservations carefully before using this product.**

### **Special warning notes for equipment with R290 refrigerant**

**Fluorinated greenhouse gases** are in a hermetically sealed system. Work on the refrigeration and electrical systems of the equipment should only be performed by the manufacturer's qualified service technician. If this requirement is not met, warranty claims will not be considered.

- This equipment contains flammable and explosive refrigerant - propane R290!
- Be sure to maintain a minimum distance of 10 cm from the walls of the equipment to the walls and surrounding objects. In any case, do not allow the air circulation for equipment with a flammable refrigerant to be disrupted!
- Do not cover the ventilation holes in the equipment enclosure.
- The equipment must be disconnected from the mains before each maintenance.
- Work on the refrigeration system should only be performed by qualified specialists (specialists trained in handling flammable refrigerants).
- Open the refrigerant circuit and pump it out only in well-ventilated rooms or outdoors. Make sure there are no unauthorized people around.
- R290 propane refrigerant must be disposed of by authorized companies in compliance with all safety standards.

### **WARNING**

- Do not allow damage to the refrigerant circuit.
- Do not use mechanical or other means to accelerate the defrosting process other than those approved by the manufacturer.
- Do not install any electrical devices in the storage chamber that are not intended by the manufacturer.

The manufacturer has the right to change the technical specification and characteristics of the equipment not impairing its functionality without prior notice to the customer. Illustrations, photos, pictures of equipment may differ from the real model.

## 1. GENERAL INFORMATION

Upright refrigerated cabinet ADX is designed for short-term storage and sale of food, previously cooled to the temperature of the cooled volume in retail stores and catering establishments.

The cabinet is designed to be used indoors at ambient temperature from +16 to +25°C and relative humidity of no more than 60%. The temperature inside the cabinet is 2°C + 8°C.

The equipment structure consists of the following elements:

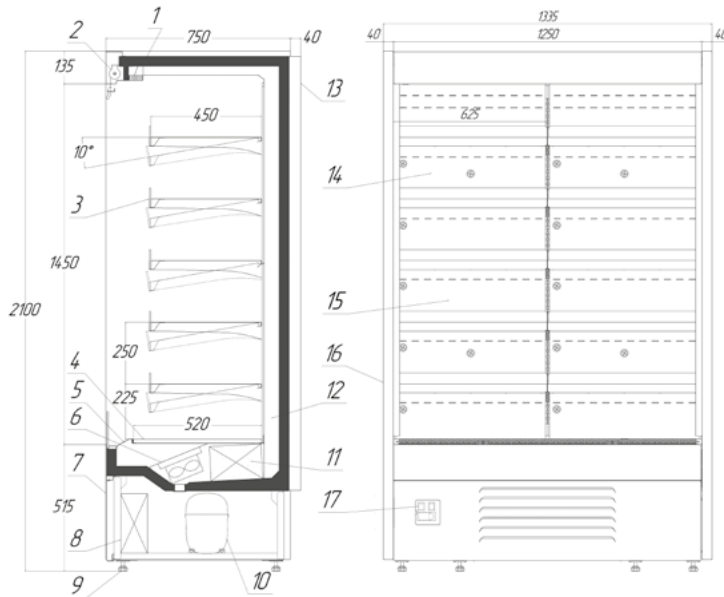

- 1 - housing;
- 2 - roller blind;
- 3 - hinged shelves;
- 4 - bottom shelf;
- 5 - air intake grid;
- 6 - evaporator fans;
- 7 - front panel;
- 8 - condenser;
- 9 - adjustable supports;
- 10 - compressor;
- 11 - evaporator;
- 12 - cold air shaft;
- 13 - rear stoppers;
- 14 - upper perforated trunking wall;
- 15 - bottom perforated trunking wall;
- 16 - side panel;
- 17 - control panel;



## 2. TECHNICAL SPECIFICATIONS

Parameters	Units of measurement	ADI125	ADI150	ADX95	ADX125	ADX150	ADX187.5	ADX250
Dimensions:								
Length without side panels	mm	1250	1500	950	1250	1500	1875	2500
Length with side panels		1310	1560	1035	1335	1585	1960	2585
Depth		900	900	800	800	800	800	800
Height		2085	2085	2000	2000	2000	2000	2000
Exposure area of one shelf	m <sup>2</sup>	3,5	4,2		3,4			
Refrigerated volume	l	1160	1390	800	1000	1250	1550	2000
Useful volume	l	930	1115	590	780	935	1170	1560
Weight of the cabinet	kg	370			290			
Refrigerant		R404a	R452a	R404a	R452a	R290		
Amount of refrigerant	kg	0,9	0,9	0,98	0,98	0,15		
CO2 EQ	t	3,56	1,93	3,84	2,10	0,00	0,00	0,00
Rated current	A	4,7			5,8			
Power consumption	kWt/24h	17,45			17,0			
Rated current (with glass door)	A	4,5			6,3			
Power consumption (with glass door)	kWt/24h	11,5			12,3			
Climate category		3						
Recommended ambient temperature	°C	+16...+25						
Operating temperature range	°C	+2...+8						
Power supply voltage	V/ Hz	220-240/50						
Cooling mode		dynamic						
Defrost mode		automatic						
Package:	pcs							
shelves feet/wheels								
Maximum load per shelf	kg	40	50		20			

### 3. TRANSPORTATION, INSTALLATION AND COMMISSIONING

#### 3.1. Transportation method

The unit requires careful protection against damage and accidental overturning during transportation. Glass elements and painted surfaces are especially vulnerable. The equipment must be in an upright (working) position both when transporting and when moving. After installing the equipment in a specific location, the network connection must be made after a minimum of 6 hours.

#### 3.2. Storage method

The cabinet must always be stored in an upright position. Do not store the equipment exposed to direct sunlight or other weather conditions (rain, snow, etc.).

#### 3.3. Operating site requirements

The equipment should be installed in a dry, well ventilated place that allows good air circulation (distance between the wall and the unit should be at least 10 cm), away from heat sources and devices that generate air flow (including fans, air conditioners).

Do not install the equipment in locations exposed to direct sunlight, rain, snow, etc.

Make sure that the cross-section of the power lines is suitable for the current power consumption.

#### 3.4. Equipment installation and preparation for operation

Place the cabinet on the work surface and level it horizontally with the adjustable supports (Figure 1). Precise horizontal positioning of the equipment affects the reduction of unit noise and guarantees condensate drainage.

Set the brackets to the desired height and install the shelves on them.

It is necessary to install the cabinet not closer than 2m from the heating devices in order to ensure its normal operation. Do not use the cabinet when it is exposed to direct sunlight, air flows from air conditioners, fans and heaters

Wash the interior and exterior surfaces of the cabinet with non-corrosive and non-abrasiv

#### 3.5. Connection and commissioning

##### Requirements for operation:

a) After transportation or storage at low temperatures, keep the cabinet at a temperature not lower than the operating temperature for 24 hours before start-up. Starting equipment that has not been warmed up can cause the compressor to jam and result in product failure

b) products intended for display in refrigeration equipment should be loaded on the shelves evenly, cooled to the temperature of the working volume;

c) place products in such a way that they do not interfere with the air circulation between the evaporator and the internal volume of the equipment;

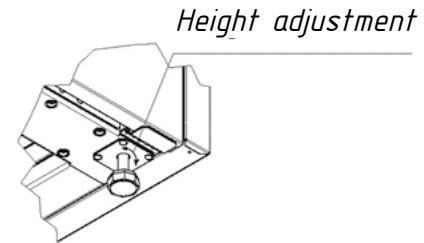

Figure 1. Adjustable supports



**DO NOT:**

- cover and block the ventilation openings of the equipment;
- install the equipment near heat sources (heaters, radiators) and under direct sunlight;
- install the equipment in draughts.

**If the requirements are not met, air circulation is impaired and product performance deteriorates, which can lead to food spoilage.**

The product compressor works cyclically, switching off when the set temperature is reached and switching on when the temperature rises by 2-3°C. At the same time, the temperature at certain points of the cooled volume may temporarily increase and differ from the controller reading, which is not a defect.

The compressor stops periodically to defrost the evaporator during the cabinet operation. When defrosting, the temperature in the cooled volume may increase, which is not a defect.

**These are the main indicators of the normal operation of a refrigerated cabinet:**

- the temperature of the internal volume corresponds to the set temperature;
- The refrigeration machine works cyclically.

The equipment must be connected to the 230 V/50Hz mains supply, for this purpose a demountable plug is provided, which makes it possible to connect both through a grounded socket and directly to the mains. Make sure that the circuit breaker (Figure 2) is turned off before doing this.

- **When plugged in, the control panel lights should turn on.**
- **Check the power supply voltage before connecting the equipment to the mains.**

**ATTENTION!**

- **The unit's compressor is adapted for operation with a supply voltage not lower than 210 V and not higher than 240 V. Operating the unit outside of these power settings can cause irreparable damage to the compressor.**
- **If the circuit breaker trips when connecting the cabinet, contact the service center.**

**Necessary safety precautions:**

1. The equipment must be connected by a qualified electrician.
2. In case of a malfunction such as a damaged power cord, sparking, etc., the equipment must be immediately disconnected from the mains.
3. Washing and cleaning can only be done after disconnecting the power supply or turning off the circuit breaker.

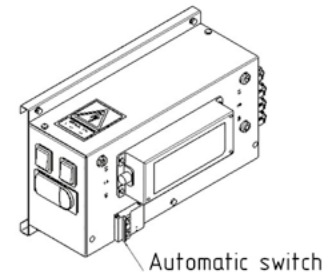

Figure 2. Control unit

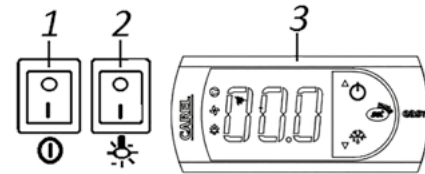

Figure 3. Control panel

4. If the power cord is damaged, it must be replaced by the manufacturer or the manufacturer's service technician or a qualified electrician in order to prevent any possible damage to life or health.

5. **DO NOT** connect the cabinet through extension cords that do not have a grounding wire, or if the cross-sectional area of the extension cord is less than 1.5 sq. mm.

### 3.6. Operation of energy-saving night blinds (curtains)

For maintaining the temperature inside the refrigerated multideck at night, the use of night blinds is recommended. In the open state, the hook of the night curtain enters the groove at the top of the multideck (left image). In order to close the window you need to pull the hook down and fix it in a special hole (right-image).

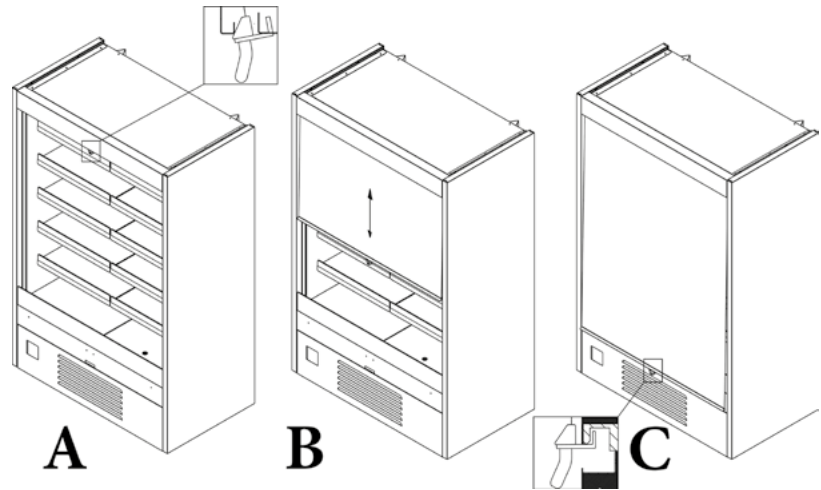

Figure 4. Operation of night blinds





### 3.7. Assembling a line of refrigerated multideck ADX

3.7.1. Remove the front glass from the connecting windows by removing it from the groove.

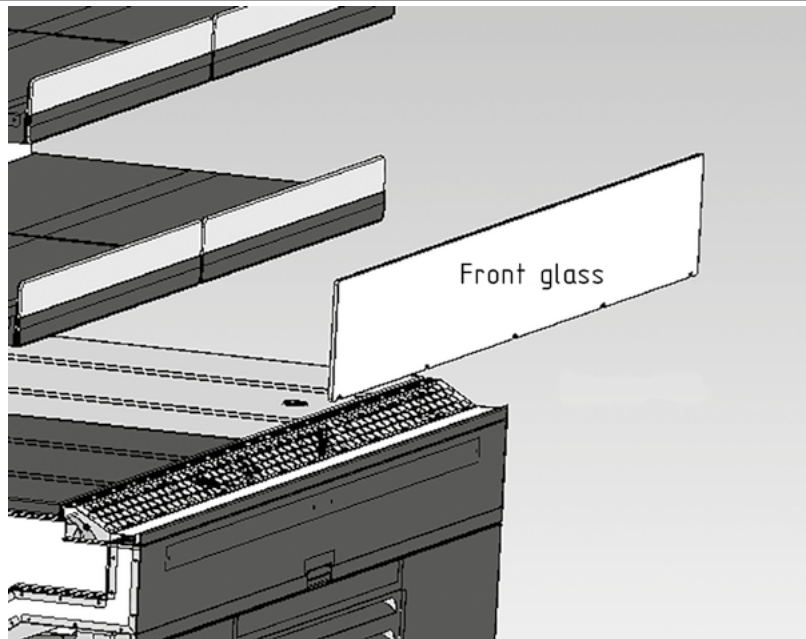

3.7.2. Remove the shelves and brackets that hold them from the side of the multideck joint. To do this, lift the shelf up to the exit of the brackets holding it out of the grooves, after the shelf is removed - remove the brackets from the grooves in the racks.

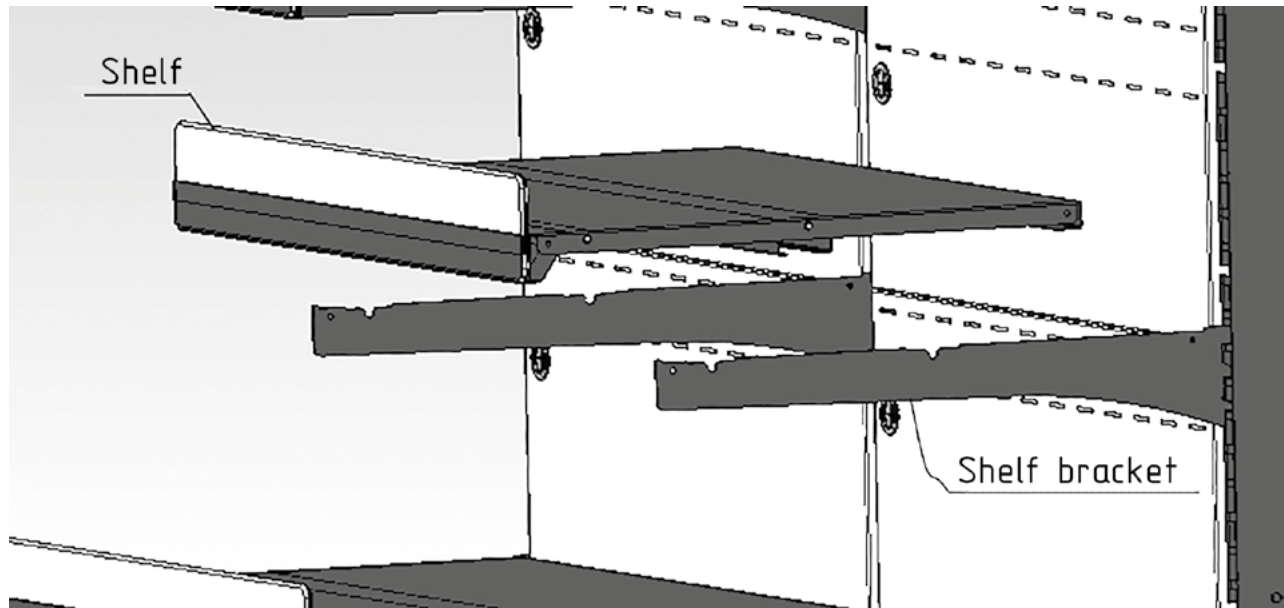



3.7.3. Remove the upper and lower perforated false walls, in the center of the false wall is a hole for interaction with it. Hook the false wall through this hole with your finger, lift it slightly until the hooks come out of the hook and pull on yourself.

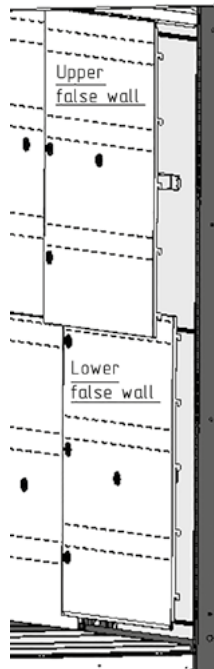

3.7.4. Remove the front panel, take the panel from under the bottom and pull on yourself, then feed the panel to the bottom to the exit upper flanges with hook.

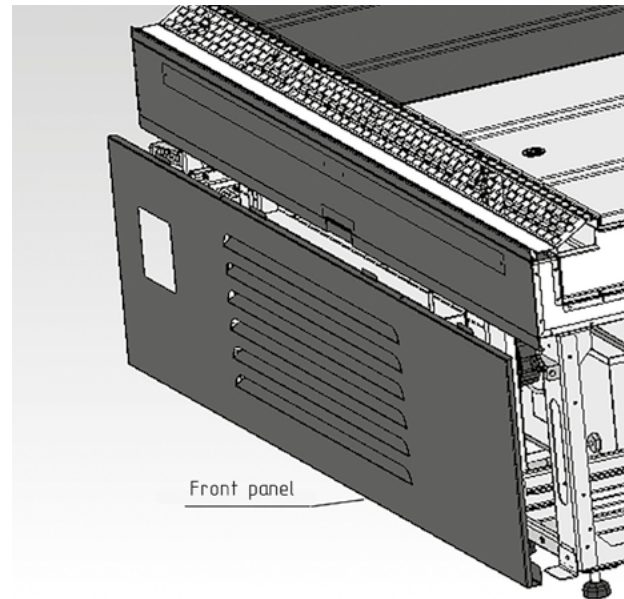

3.7.5. Unscrew the self-tapping screws and remove the rack plugs on the connection side

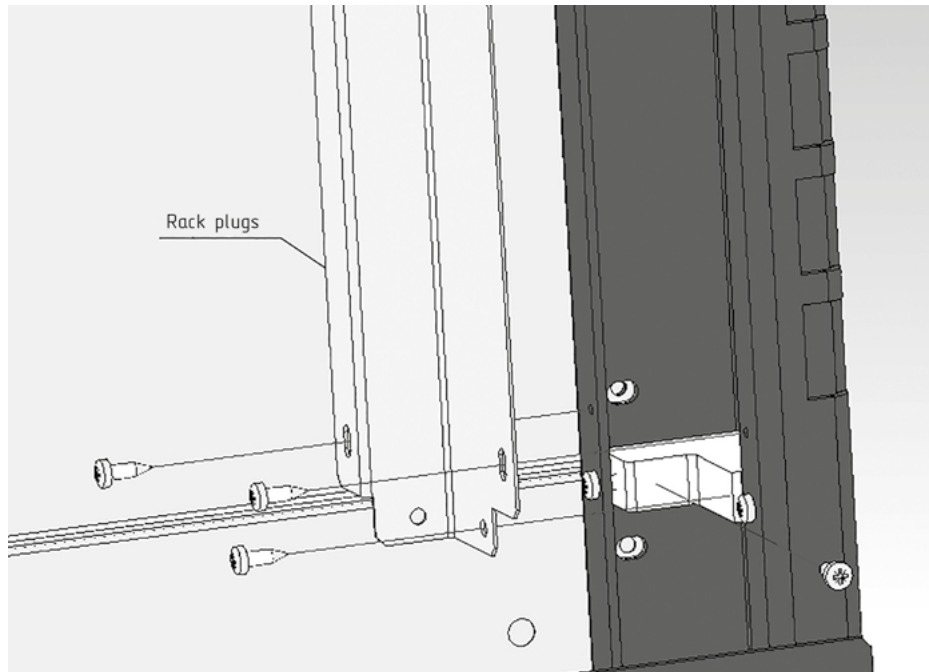



3.7.6. If the side panel is installed - unscrew the bolts securing it and remove the side panel (note, for convenience, it is recommended to place under the side panel supports made of soft material (wood, plastic, foam, etc.) to prevent fall side panel and paint damage).

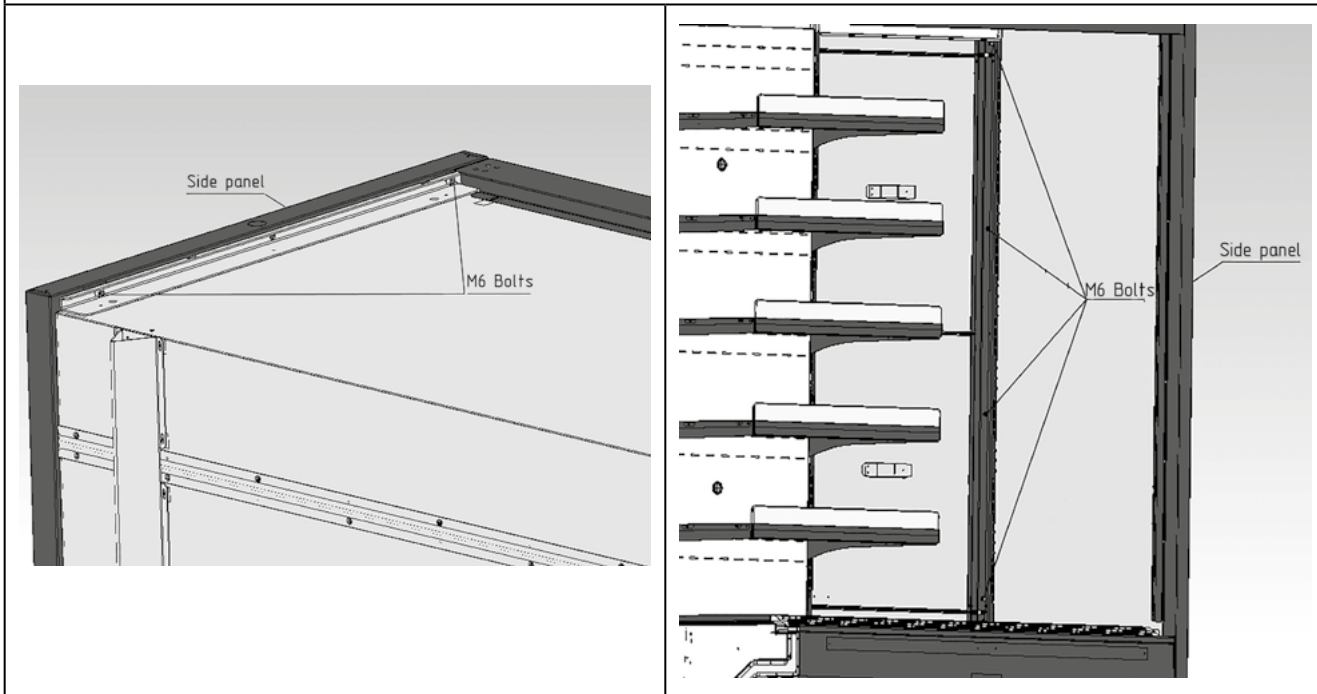

3.7.6. If the side panel is installed - unscrew the bolts securing it and remove the side panel (note, for convenience, it is recommended to place under the side panel supports made of soft material (wood, plastic, foam, etc.) to prevent fall side panel and paint damage).

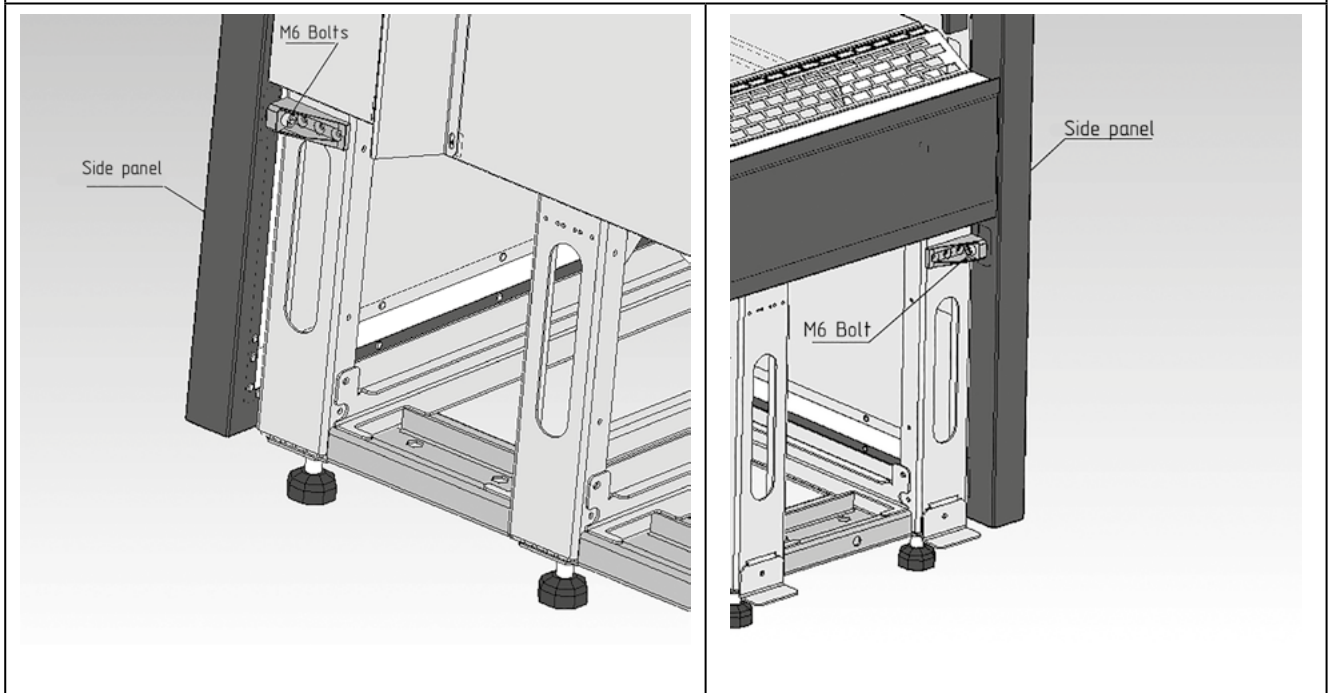



3.7.7. Apply a butyl cord  
d = 4 mm at the junction of  
the display case. In the case of  
connecting display case without  
a partition - application to only  
one of the display cases.

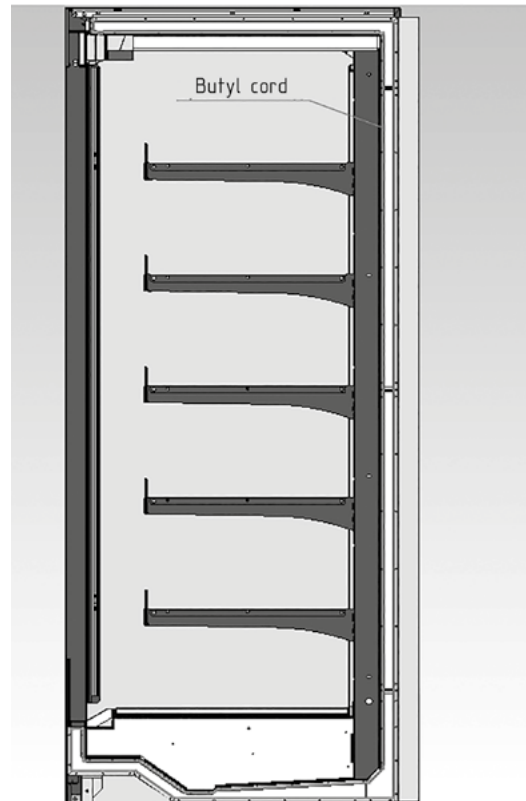

3.7.8. Only for the option of installing a blank panel !!!  
Attach the blank panel with M6x16 bolts (use two M6x25 bolts at the bottom of the panel), similarly attach the second multideck to the panel on the opposite side. (note, for convenience it is recommended to substitute supports made of soft material (wood, plastic, foam, etc.) under the blank panel to prevent its falling and damage to the paint).

Assemble multidecks in a line according to their final configuration, keeping the distance at least 30 cm.

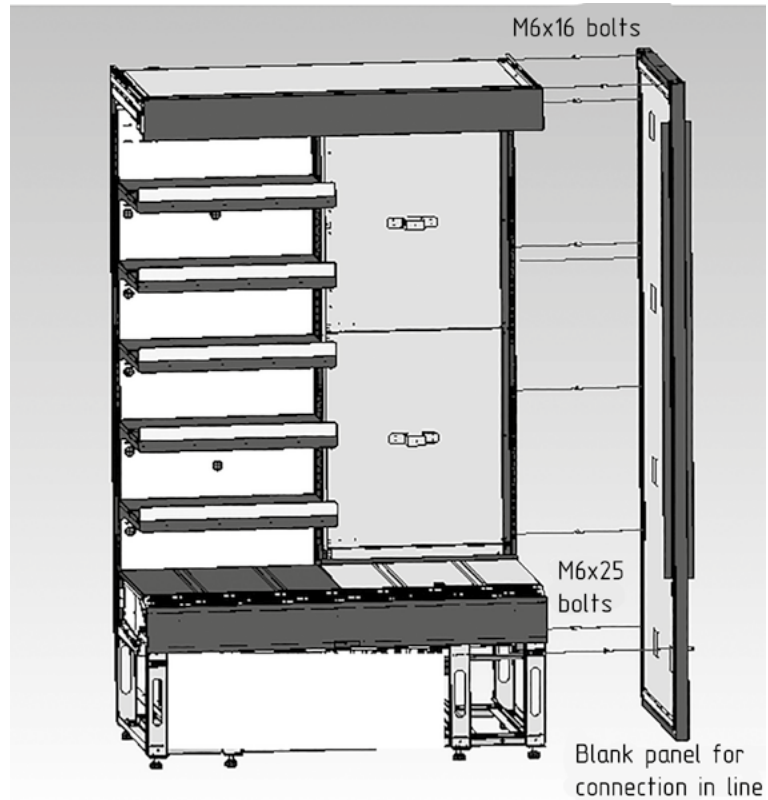





3.7.9. Only for the option of connecting without partitions !!! Install the air duct plug, for which you need to put the cap on the flange of the upper panel while inserting the deflection of the cap between the foam insert and the bends of the parts

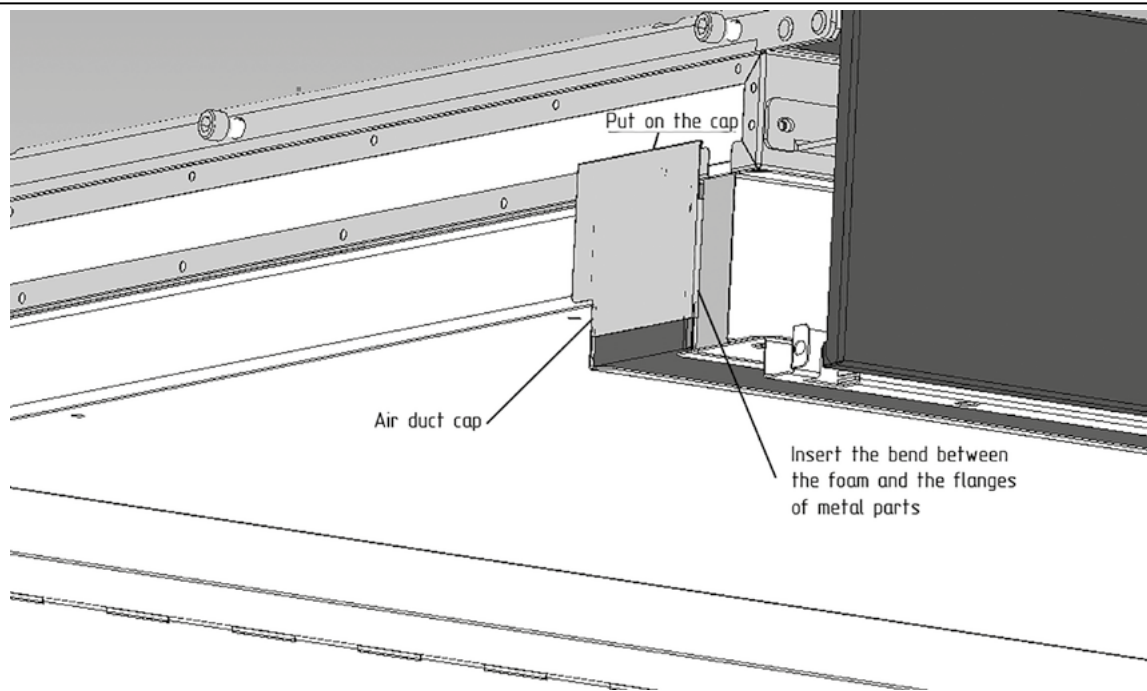

3.7.10. Connect the display cases to each other, or through a jumper made of plexiglass through the upper bracket and side post with bolts M6x16 (M6x25 when using a partition made of plexiglass), connect the two lower mounts of the frame with M6x45. Secure the connection with M6 self-locking nuts

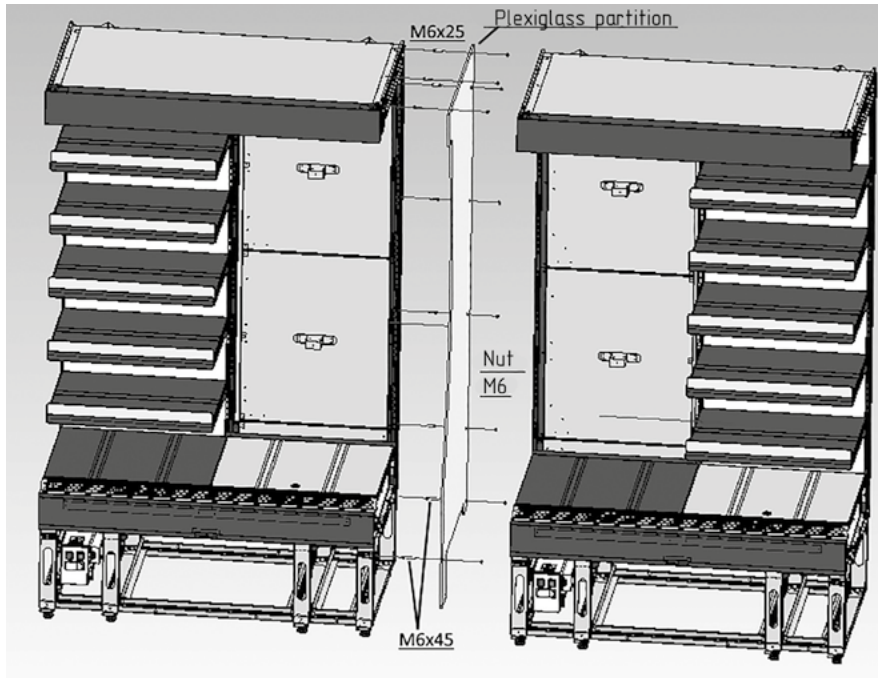



## 4. OPERATION

### 4.1. Operating procedure of the CAREL electronic controller

#### 4.1.1. Light signals on the electronic controller display

##### • Indicating LEDs on the display

**Light signal a - compressor:** the symbol is visible when the compressor is running. Blinks if the compressor start is delayed by a safety procedure.

**Light signal b - fan:** The symbol lights up when the fans are on. Blinks when the start of the fans is delayed by an external shutdown or during another procedure.

**Light signal c - defrost:** the symbol is visible when the defrost function is on. Blinks when defrost start is delayed by an external shutdown or during another procedure.

**Light signal d - alarm:** the symbol is visible when the alarm is active.

**Signal e - displays the temperature** inside the equipment.

#### 4.1.2. Temperature setting

##### • In order to set the temperature:

1. Press 2, SET appears on the screen, after 1 second the flashing temperature value will appear;
2. Increase or decrease the temperature using keys 1 and 3; 3. Press 2 again to confirm the new value

#### 4.1.3. Additional defrosting

The device operates in automatic defrosting mode with an interval of 5-6 hours. If you notice that the defrosting does not occur or occurs incompletely, perform a manual defrosting. To do this, press 3 and hold it for 3 seconds (the defrost indicator will appear on the display) (**signal c**). The system will automatically defrost the evaporator.

#### 4.1.4. Warning signals:

„E0” - temperature sensor failure

„E1” - defrost sensor failure

„cht” - warning signal (condenser clogging)

„CHt” - dirty condenser alarm.

### 4.2. Operating procedure of the DIXELL electronic controller

#### 4.2.1. Display

1. Thawing; 2. Compressor operation; 3. Evaporator fan operation (in some models it signals condenser fan operation); 4. Temperature indication.

The blinking value of the indicator signals a program delay.

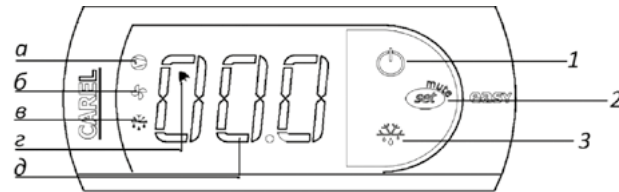



Figure 5. CAREL electronic controller

#### 4.2.2. Checking the set temperature.

- Press briefly the SET button (8), then the set temperature will appear on the screen;
- Press the SET button (8) briefly or wait for 5 seconds to return to the normal display.

#### 4.2.3. Temperature change. To change the set values::

- Press the SET button (8) for more than 2 seconds. The set temperature value will be displayed and the "°C" or "°F" indicator will flash;
- To change the temperature, press keys  (5) and  (6) for 10 seconds;
- To confirm the new value, press SET (8) or do not press the keys for 10 s.

#### 4.2.4. Manual defrost request (if provided by the manufacturer).

- Press button (7) for more than 3 seconds  (7), then the defrost will start, which will be signaled by the indication.

#### 4.2.5. List of alarms.

**da** - open door alarm: when the door is opened, the controller starts counting down, blocking the operation of the air cooler fan. After this time has elapsed, an alarm is triggered and the change controller displays a «**da**», signal, during which the fan operation is resumed. The alarm is reset automatically when the door is closed.

**P1** - temperature sensor failure; **P2** - evaporator temperature sensor failure;

**HA** - high temperature in the chamber: alarm of excessively high temperature in the chamber, can indicate equipment malfunction. The alarm is turned off automatically when returning to normal operation.

**LA** - low temperature in the chamber: alarm of extremely low temperature in the chamber, can indicate equipment malfunction. The alarm is turned off automatically when returning to normal operation/

**WARNING: IN THE EVENT OF FAILURE TO COMPLY WITH THE RULES SET FORTH IN THIS MANUAL CONCERNING THE CONNECTION AND OPERATION OF THE EQUIPMENT, THE MANUFACTURER'S WARRANTY WILL NOT BE VALID.**

Technical parameters contained in the manual are subject to change by YUKA-Invest LLC without notice to the user. Images and figures may differ from the actual configuration.

## 5. PRESERVATION

### 5.1. Cleaning and preservation

The user should perform periodic maintenance:

1. Wash the interior and exterior surfaces of the cabinet. Wash after unplugging or disconnecting the circuit breaker, using warm water with non-corrosive and non-abrasive detergents.



Figure 6. DIXELL electronic controller



2. The electrical part does not require any maintenance other than visual inspection of the external protective or insulating materials.
3. Periodically perform a visual inspection of the cold volume fans for operability and presence of debris. To do this, remove the lower shelves (Figure 6) (1 - right lower shelf, 2 - shelf extraction insert, 3 - left lower shelf, 4 - front panel)
4. The refrigeration system requires no maintenance other than periodic cleaning of the condenser.

#### 5.1.1. Equipment cleaning

##### IT IS FORBIDDEN:

- to use a water jet to clean the equipment, only a damp cloth is allowed;
- to use any sharp objects in order to remove dirt;
- to use mechanical and thermal means to accelerate the defrosting process.

#### 5.1.2. Defrosting the evaporator

The cooling unit is equipped with an automatic evaporator defrosting system - with intervals of 5 to 6 hours. In case of incomplete defrosting it should be done manually (see paragraph 4.1.3.).

#### 5.1.3. Condenser maintenance

The user must keep the condenser clean. Contaminants make heat transfer difficult, resulting in increased energy consumption as well as damage to the compressor.

##### **ATTENTION! THE CONDENSER SHOULD BE CLEANED AT LEAST ONCE A MONTH.**

Condenser maintenance:

- disconnect the device from the power supply;
- remove the front panel (figure 7) covering the unit;
- using a soft brush, clean the condenser of dust, packaging residues, etc. (figure 8);
- After cleaning, install the front panel back in place.

In case of serious contamination (clogging of the blades) it is recommended to use an air compressor or compressed nitrogen in order to suck out / blow out the contamination between the blades.

The compressor is equipped with an internal back-up (thermal) switch to protect the motor from accidental overloads.

If you hear unusual, loud operation or heavy compressor starts, turn off the unit, check the condition of the condenser (clean it if dirty).

**ATTENTION! Failure to perform this maintenance can result in difficult starting of the compressor, loud machine operation, overheating of the compressor and consequent deterioration of cooling efficiency.**

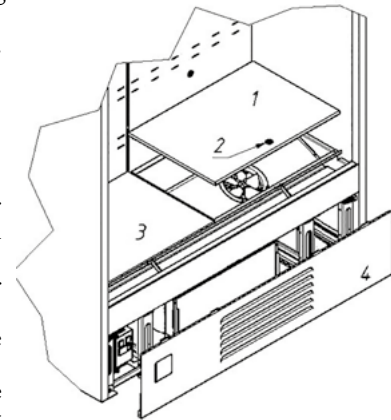
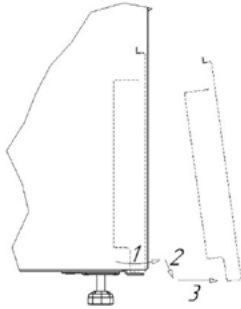
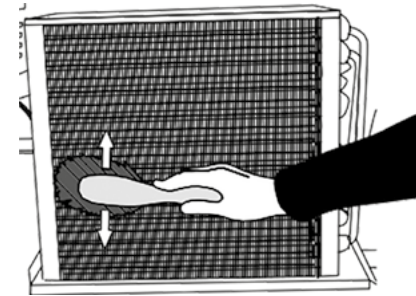

Figure7. Cleaning the condenser



*Holding the front panel by its bottom part, pull it toward you until the front panel comes out of the support brackets, then lower the front panel until it comes out of the upper slots, pull the panel out*

**Figure 8. Front panel**



**Figure 9. Cleaning the condenser**

The manufacturer is not responsible for any damage to the compressor caused by contamination of the condenser.

#### **5.1.4. Miscellaneous**

Equipment components can corrode if not used and maintained properly. To prevent this, the following rules should be followed:

- Do not allow the surface of the equipment to come into contact with agents containing chlorine or soda of various grades; they will destroy the protective layer and accessories (this also applies to various types of stainless steel).
- During maintenance operations, take care not to damage the equipment nameplate, which contains important information for service personnel and waste disposal companies.

## **6. IDENTIFICATION AND ELIMINATION OF MALFUNCTIONS**

If you have any problems with the operation or start-up of the equipment, refer to the sections of the manual dealing with abnormal operations. The purpose of this is to verify proper maintenance of the equipment. If the problem persists, try one of the suggestions given below.

× **If the equipment does not work, make sure that:**

- The device is connected to the power supply.
- The mains voltage and frequency correspond to those recommended by the manufacturer - 220-240 V/50 Hz.
- The main switch is turned on.
- The controller is turned on.

× **In case water leaks from under or inside the chamber:**



- Check that the equipment is properly aligned.
  - Check the drainage system for permeability.
  - Empty the container or condensate tray.
  - × **If the power cord is damaged:**
  - If the power cord is damaged, it must be replaced in order to avoid a hazard. To do this, contact the service department, the manufacturer, or qualified personnel. **The WARRANTY MAY be null** and void if the work is performed by non-certified personnel!
  - × **In the case where only the unit is running, but without the lights, check the:**
    - Light switch is on
    - LED lamp or starter in the equipment has not burned out
  - × **In case the lights work but the unit does not reach the set temperature, check the following:**
    - The main switch is on.
    - The temperature setting on the controller is correct and the controller is operating correctly.
    - The condenser is not clogged (clean it if necessary).
    - The ambient temperature does not exceed 25 °.
    - The food remains inside the cabinet long enough to cool down.
    - The cabinet does not contain too many products and does not exceed the maximum cooling capacity.
    - The air vents are not blocked.
    - The evaporator is not covered with ice. If necessary, carry out a complete preventive defrosting of the equipment, having previously moved the food to another place with an appropriate temperature mode.
  - × **In case the equipment is too loud, check the following::**
    - The equipment is installed securely and properly aligned.
    - Furniture adjacent to the equipment does not vibrate during compressor operation.
    - The internal elements are installed correctly.
  - × **Clogged condenser failure (CHT, CHT)::**
    - cht** - the warning signal of a clogged condenser failure. Indicates that the condensing temperature is approaching a critical level. Displayed with the current temperature, while continuing normal operation. The signal disappears automatically if the condenser temperature normalizes.
    - CHt** - clogged condenser failure. Indicates that the critical condensing temperature has been exceeded. It is accompanied by stopping the cooling unit operation, an acoustic alarm (press SET to stop the acoustic alarm) and a variable display of CHt, cht and temperature in the chamber on the controller's display.
- WARNING: the "CHt" signal can only be reset manually by turning off the equipment (when the equipment is turned on, if the**

**condenser temperature does not normalize, the alarm will be triggered)**

. (Applies to CAREL thermostat) The thermostat displays E0/E1/L0/HI/EE/Ed/DF instead of temperature:

- E0 - temperature sensor inside the chamber is damaged - contact an authorized service;
- E1 - evaporator sensor is damaged - contact an authorized service.

**ATTENTION! Noise produced by equipment during operation is a normal phenomenon. The equipment contains fans, motors and compressors that turn on and off automatically. Each compressor generates a certain level of noise during operation. These sounds are created by the unit's motor and the refrigerant moving through the circuit. This phenomenon is a technical property of the refrigeration equipment and is not a sign of malfunction.**

If, after checking the items mentioned above, the equipment does not work correctly, contact JUKA Technical Center, indicating the data from the nameplate.

**JUKA service center phone number: +38 (097) 524 84 11**

**e-mail: [service@juka.ua](mailto:service@juka.ua)**

## **7. DISPOSAL**

In cases where the equipment becomes unusable, it must be disposed of. Disposal must be carried out in accordance with the rules and regulations in force in each individual country. It is advisable to contact authorized disposal companies that are engaged in the disposal of the respective equipment in an environmentally friendly manner.

**ATTENTION! ALL DISPOSAL OPERATIONS AS WELL AS THE TRANSPORT AND HANDLING OF WASTE MUST BE PERFORMED ONLY BY SPECIALISTS AND AUTHORIZED PERSONNEL.**





## ATTENTION!

Keep the warranty card for the entire duration of the warranty period.

With this warranty, the seller and the service center assume the obligation to remedy defects caused by the manufacturer at no charge during the warranty period. The warranty card is valid only if it correctly and clearly indicates: the model, serial number of the equipment, date of sale, clear seal of the seller.

### **Warranty repair may be refused in the following cases:**

- information about the equipment in the card is incomplete, illegible, unreliable (discrepancy with the information on the equipment), there is no signature of the buyer;
- incorrect installation, improper transportation of the equipment, unsatisfactory condition of the condenser and lack of proper maintenance by the user (see Operating Manual);
- the presence of mechanical damage could lead to improper operating conditions or failure of the equipment;
- failure to comply with the terms of the manual in the equipment's operation or in case of false actions by customers;
- If a natural disaster or a standard insurance event has occurred, resulting in the impossibility of further operation of the equipment (flooding, fire, theft, etc.), as well as under other circumstances beyond the control of the seller, manufacturer.
- when traces of any foreign objects, liquids, insects, etc. are found inside the equipment, as a result of which the equipment has malfunctioned;
- unqualified repairs or any structural modifications to the system by unauthorized persons;
- if the damage defects occurred due to non-compliance of the stream and cable network parameters with the requirements of state standards.

**WARRANTY MAINTENANCE DOES NOT COVER** periodic maintenance, installation, adjustment of equipment for operation, or cable replacement.

The warranty does not cover easily breakable parts of the equipment that are considered consumables by factory standards: lamps, glass, plastic (handles, etc.), rubber, locks, wheels, etc.

The above warranty service does not diminish the purchaser's legal rights granted by applicable law.

The buyer shall be notified that if a service technician is called to the location of the equipment and a non-warranty failure is found, the buyer shall reimburse the service technician for travel expenses and, if desired, use the service technician's services at the manufacturer or seller's rates to correct the defects in the equipment.

## Warranty card

Product and model \_\_\_\_\_

Date of sale \_\_\_\_\_

Serial number \_\_\_\_\_

Warranty period \_\_\_\_\_

**The buyer confirms the technical serviceability of the product/**

\_\_\_\_\_  
Seller's signature

\_\_\_\_\_  
Buyer's signature



tmjuka



juka\_invest



juka.ua



juka-invest



tmjuka



+3 80 412 445 755  
+3 80 67 411 05 80



[juka@juka.ua](mailto:juka@juka.ua)

Виробник має право без попереднього сповіщення змінювати технічну специфікацію і характеристики обладнання, що не погіршують його функціональність.  
Наведені ілюстрації, фото, картинки обладнання можуть відрізнятися від реальної моделі.

The Producer reserves the right to alter the functions and technical specification of their equipment. The pictures are provided on an illustrative basis for products presentation purposes only.

Producent zastrzega sobie prawo do zmiany specyfikacji technicznych i właściwości sprzętu bez uprzedzenia, co nie wpływa negatywnie na jego funkcjonalność. Podane ilustracje, zdjęcia, zdjęcia sprzętu mogą odbiegać od rzeczywistego modelu.

Производитель имеет право без предварительного уведомления изменять техническую спецификацию и характеристики оборудования, не ухудшающие его функциональность.  
Представленные иллюстрации, фото, картинка оборудования могут отличаться от реальной модели.